

PMC Drawing Number:SR-004-□□□

1. Material:55P PVC, UL94V-2, DEHP, DINP is less than 0.1%.
2. Color Available: RD=Red, OR=Orange, YL=Yellow, GN=Green, BL=Blue, PU=Purple, BK=Black  
GY=Gray, WH=White
3. Packaging Quantity: ⊕=1000pcs, ⊕=500pcs, ⊕=250pcs,  
⊖= 200pcs, ⊖=100pcs, ⊗= 50pcs,  
⊙= 25pcs, ⊚= 10pcs

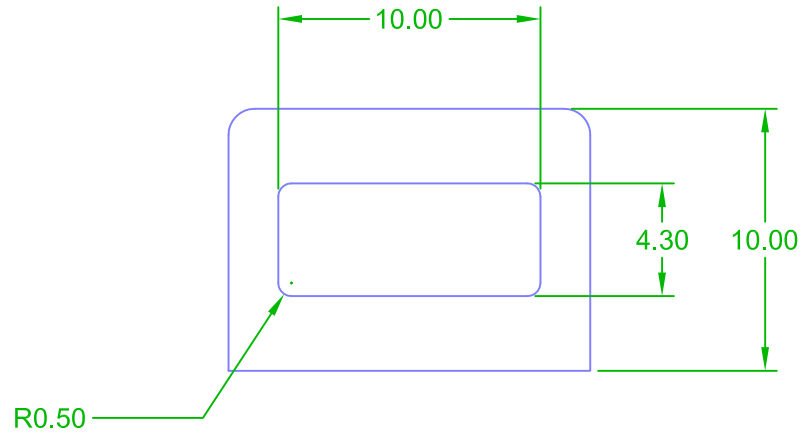

SR-004-□□□  
 □□□ Packaging Quantity (S, T, U, V, W, X, Y, Z)  
 □□□ Color (RD, OR, YL, GN, BL, PU, BK, GY, WH)

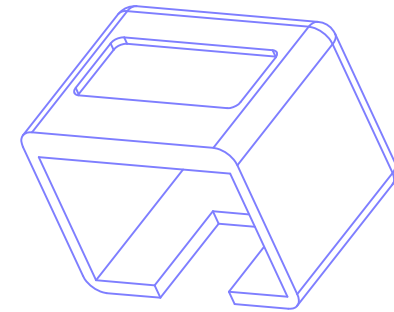
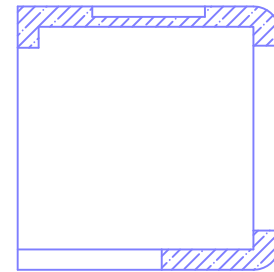
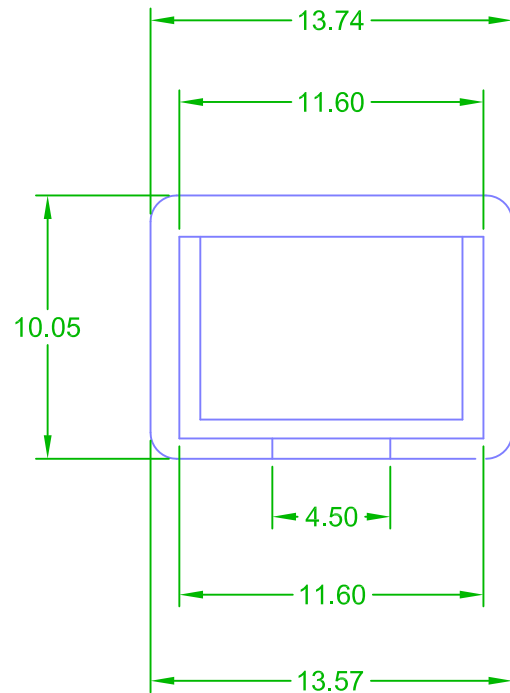

NOTE TOL:±0.15

|     |                                 |       |     |          |              |      |            |                                      |        |
|-----|---------------------------------|-------|-----|----------|--------------|------|------------|--------------------------------------|--------|
| B   | 2018.01.25. Rescheduling coding | 3RD   | ⊕   | Drawing  | <i>Chidy</i> | Date | 2009/09/19 | Part.NO                              | SR-004 |
| A   | An initial version              | Unit  | m/m | Checked  | <i>Chris</i> | Date | 2009/09/19 | Description                          |        |
| Rev | Description                     | Scale | 1:1 | Approved | <i>Jason</i> | Date | 2009/09/19 | Short Boots<br>without latch protect |        |



**Plug Master**  
 INDUSTRIAL CO., LTD  
 www.plugmaster.com.tw